

Technical Datasheet



R&Mfreenet Advanced Cat 6_A Unshielded Connection Module

R&Mfreenet Advanced Cat 6_A Connection Module

The R&Mfreenet Cat 6_A unshielded connection modules, part of the Advanced cabling system, are ideal for voice, fast data transmissions and high bandwidth applications. This high-performance Cat 6_A module is perfect for use in 10 Gigabit Ethernet (10GBASE-T) and future high-speed applications to 500 MHz.

R&Mfreenet Advanced Cat 6_A Features

Exceeds the Cat 6_A specification (mated) for the entire re-embedded plug range as specified by IEC 60603-7-41 and IEC 60512-27-100.

Exceeds the Cat 6A specification (mated) for the entire re-embedded plug range as specified by TIA/EIA 568-C.2

Attains Cat. 6_A values together with Cat. 6_A patch cables as specified in standard IEC 11801 Ed 2.2, June 2011, and EN50173-1: May 2011.

Achieves exceptional margins when installed as part of an R&M Cat 6_A unshielded channel or permanent link, exceeding the IEEE 802.3an minimum requirements for 10GBASE-T performance, as well as the requirements for Class E_A performance according to ISO/IEC 11801 ed. 2.2, June 2011, and Cat. 6A performance according to TIA/EIA 568-C.2.

Achieves best transmission characteristics with R&Mfreenet Advanced Cat 6_A patch cables

Gold-plated contact area and tin-plated insulation displacement contact area

Capacitive and inductive compensation

Compatible with Cat 6_A standard patch cords and cables

Automatic cutting of wires for precise, consistent termination

X-Separator isolates pairs from each other, minimizing influence of cable termination on NEXT performance

Use of all four sides of modules maximizes distance between pairs for optimum performance

Unique cable handling part design maximizes space for routing wires without sacrificing density

RJ-11 compatible

Fits into all R&Mfreenet patch panels and most outlets, as well as in selected vendors' faceplates by using specific adapters

Connection of installation cables of AWG 22-26 plus stranded cables of AWG 22/7 – 26/7 w/o special tools

Wiring option according to TIA/EIA 568 A and B without splitting of pair 3,6

Easy to read color wiring chart

Integrated production date for quality tracing

PoE and PoE+ compatible

GHMT and 3P certified

Standards

IEC 60603-7-41: Electrical Characteristics of the Telecommunication Outlets

ISO/IEC 11801, Ed. 2.2: June 2011

EN50173-1: May 2011

Mechanical Data

Number of RJ45 jacks	1
Number of signal contacts	8/jack
Operating temperature range	-10°C to 60°C
Storage temperature range	-40°C to 70°C
Humidity	95% (non-condensing)
Contact material	CuSn
Contact area plating	1.2 µm gold over nickel
IDC* plating	Tin-plated
Cutting blade material	Stainless steel
Housing material	Polycarbonate (UL-94-V0)
Admissible wire Ø	0.4 mm (AWG26) – 0.65 mm (AWG22)
Admissible strand Ø	AWG26/7 – AWG22/7
Admissible insulation Ø	0.8 mm – 1.6 mm
Cable diameter	10 mm maximum
Cable strain relief	Through cable tie

*IDC: Insulation Displacement Contact

Description	Standard value	Relevant Standard	Typical value (at 20°C)
Mating cycles min.	> 750	ISO/IEC 11801 2 nd Ed.	> 1000
Re-terminations**	> 20	ISO/IEC 11801 2 nd Ed.	> 20

**Re-terminations may be performed with wire that is either larger or up to two wire gages smaller than wire originally terminated.

Dimensions unshielded

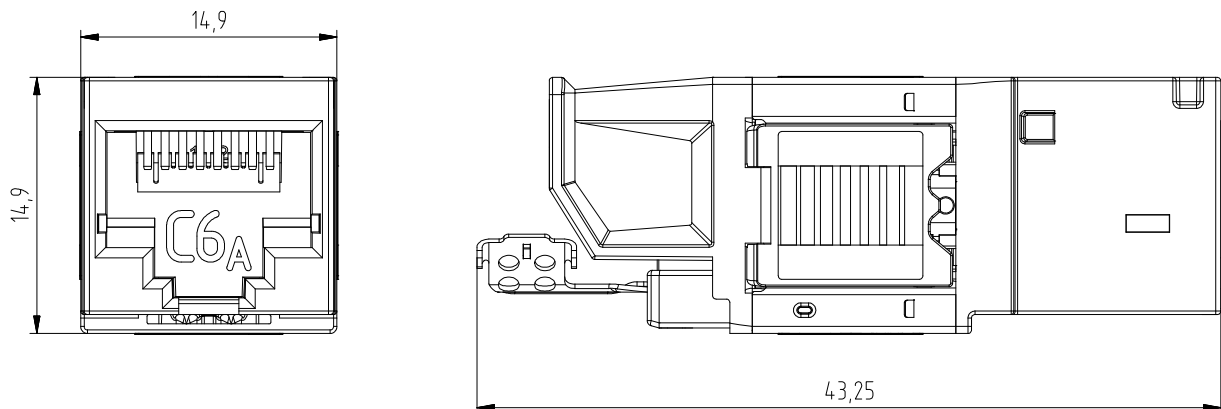

Electrical Data

Description	Standard value	Relevant standard	Typical value (at 20°C)
Electric strength			
Contacts	1000 V DC or AC peak	IEC 60603-7-41	> 1000 V _{eff}
Insulation resistance	> 500 MΩ (100 V DC)	IEC 60603-7-41	> 5 GΩ (100 V DC)
Contact resistance	< 20 mΩ	IEC 60603-7-41	< 5 mΩ
I/O resistance	< 200 mΩ	IEC 60603-7-41	60 mΩ
I/O resistance unbalance	< 50 mΩ	IEC 60603-7-41	30 mΩ
Current carrying capacity	1 Amp @ 60°C	IEC 60603-7-41	Pass

Frequency (MHz)	Insertion Loss (20°C) [dB]	Return Loss (20°C) [dB]	NEXT (20°C) [dB] all pair combinations	TCL (20°C) [dB]	PS ANEXT (20°C) [dB]
1.0	> -0.05	-48.3	-97.3	-84.4	-81.2
4.0	> -0.05	-49.2	-86.2	-73.6	-83.2
10.0	> -0.05	-46.1	-80.0	-66.1	-81.1
16.0	> -0.05	-44.3	-79.7	-62.2	-79.2
20.0	> -0.05	-43.9	-73.2	-60.3	-80.8
31.0	> -0.05	-42.6	-69.5	-56.6	-81.2
62.0	> -0.05	-38.2	-63.4	-50.8	-84.2
100.0	> -0.05	-32.6	-59.5	-47.3	-80.5
125.0	> -0.05	-30.3	-57.7	-45.5	-78.6
155.0	> -0.05	-28.5	-55.4	-43.5	-76.8
175.0	> -0.05	-27.2	-54.1	-42.7	-76.1
200.0	-0.06	-25.7	-52.6	-42.0	-74.7
250.0	-0.08	-23.6	-49.8	-40.1	-72.8
300.0	-0.12	-21.7	-47.4	-38.5	-70.9
400.0	-0.23	-19.7	-41.6	-35.6	-69.5
500.0	-0.42	-17.6	-37.3	-33.5	-66.9

Insertion Loss

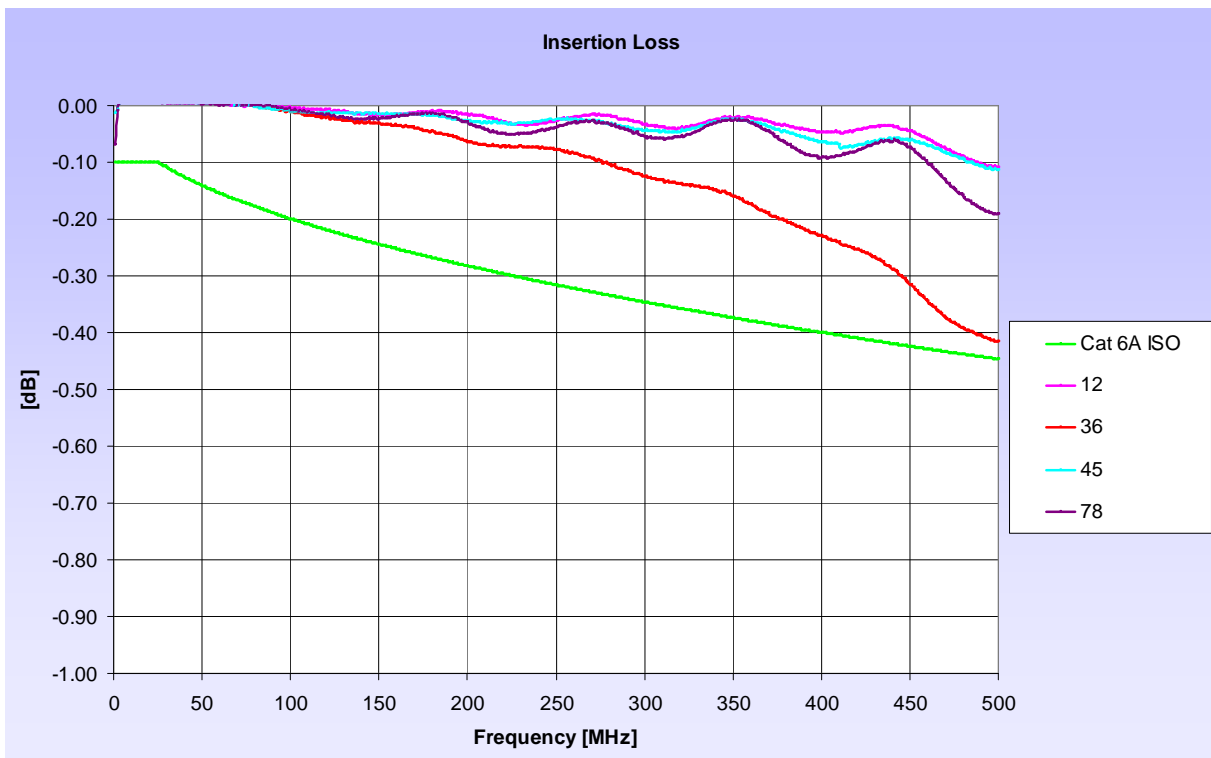

Return Loss

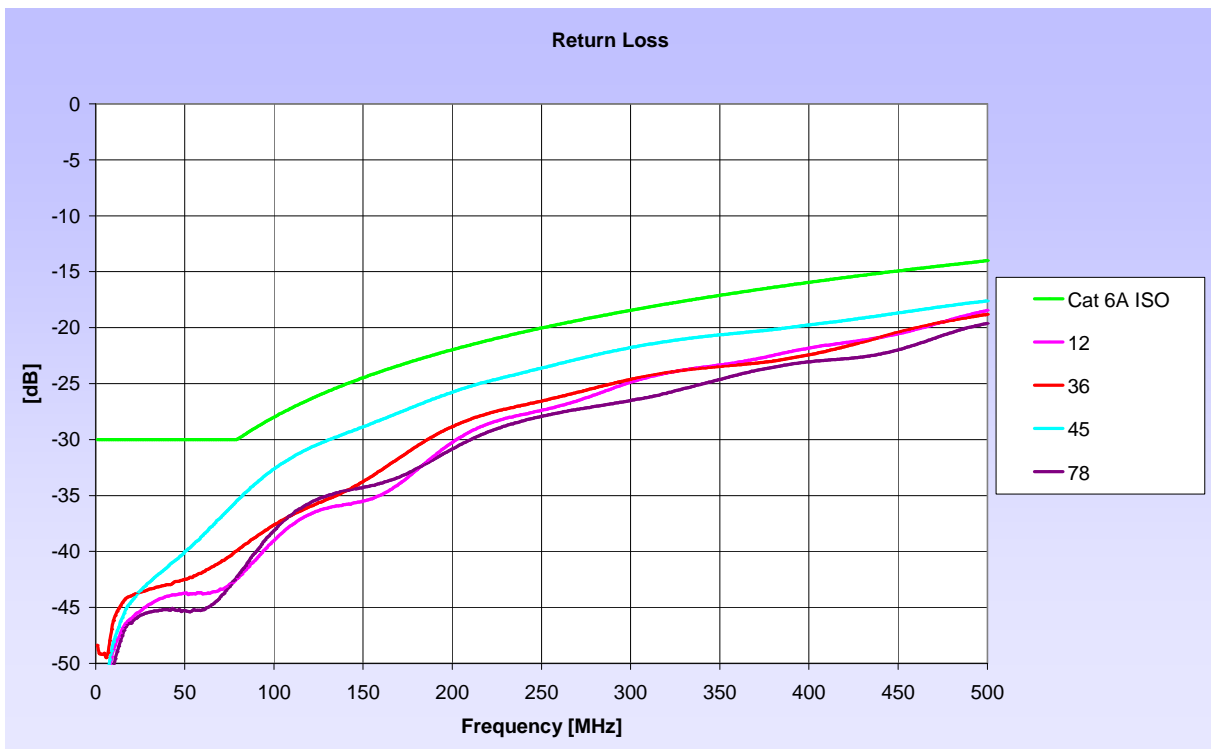

NEXT 36-45

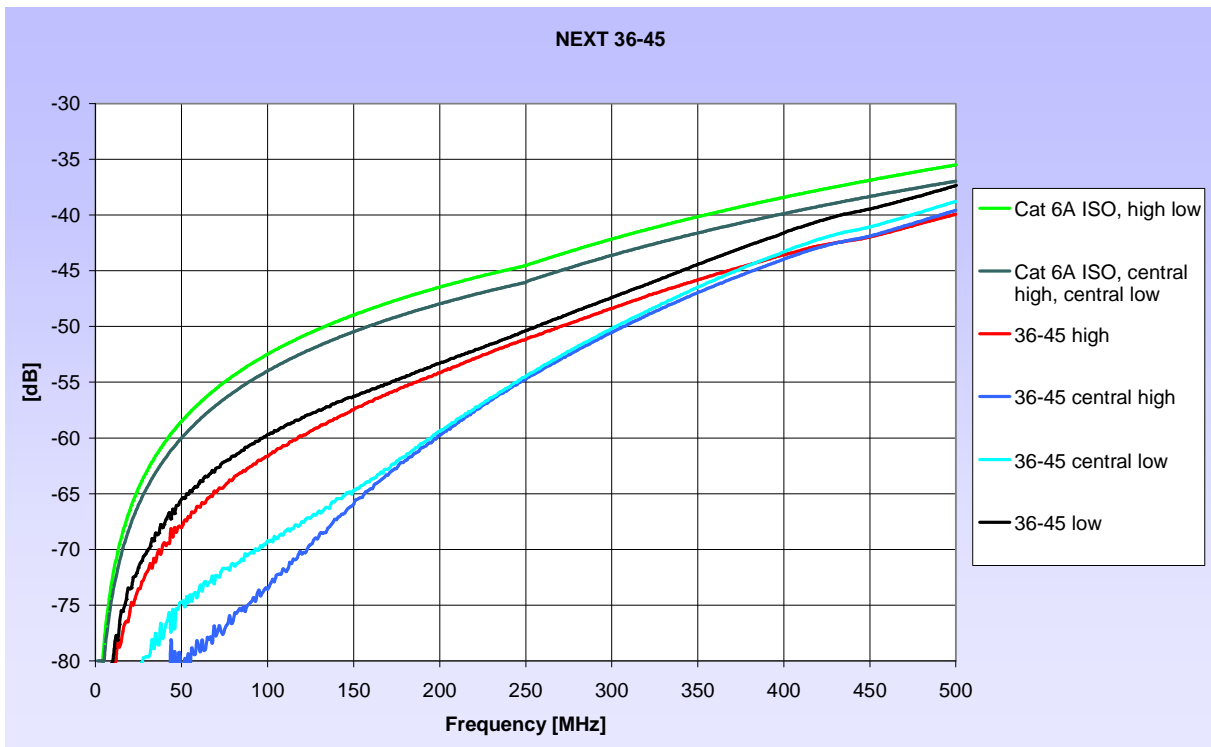

NEXT 45-12, 45-78

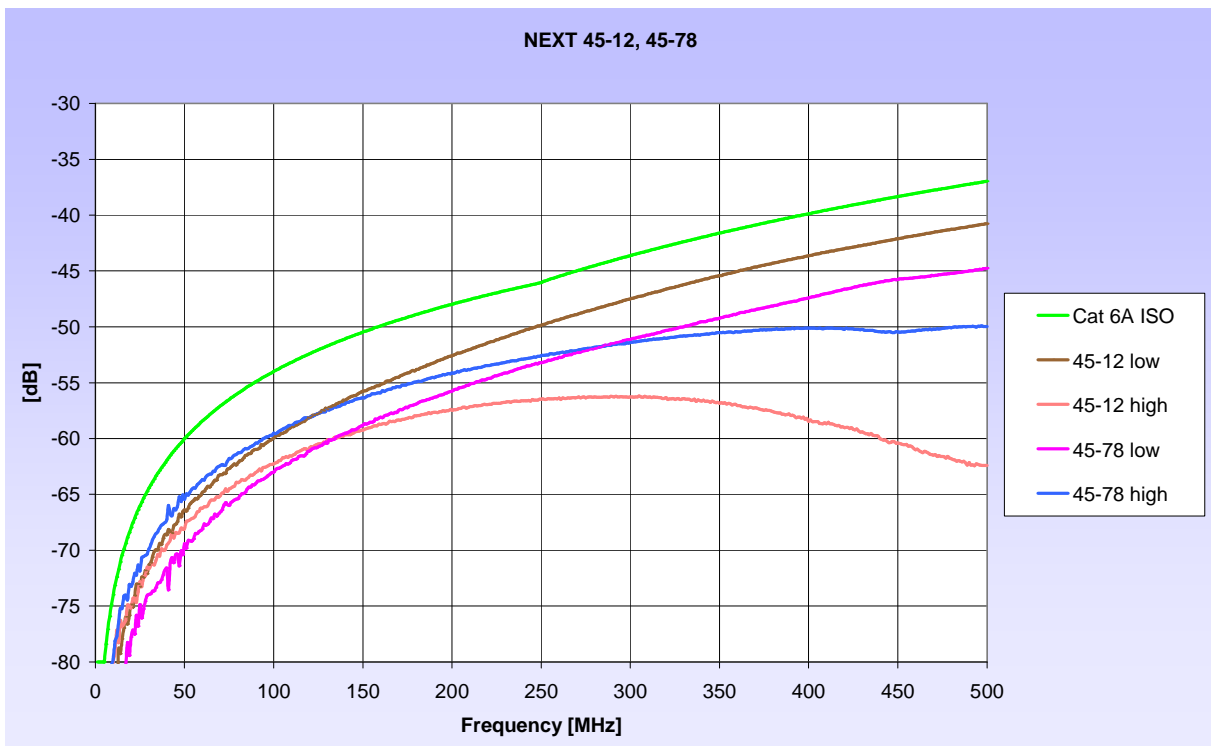

NEXT 36-12, 36-78

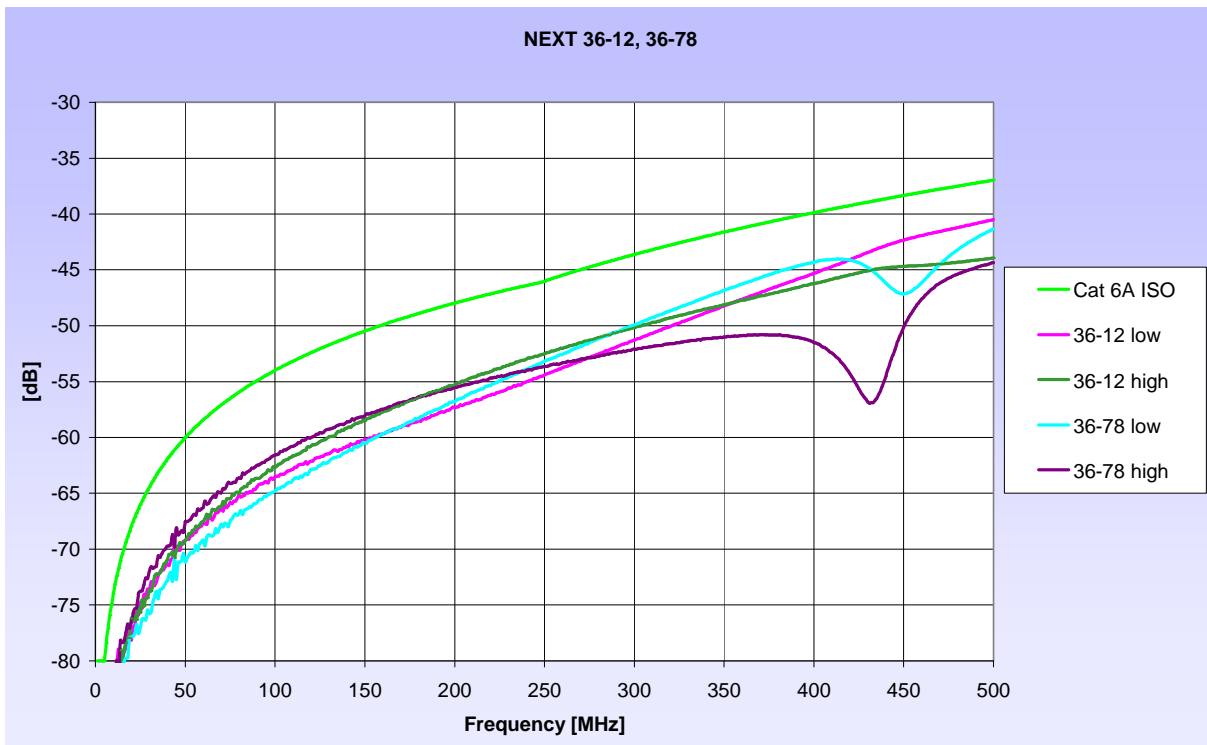

NEXT 12-78

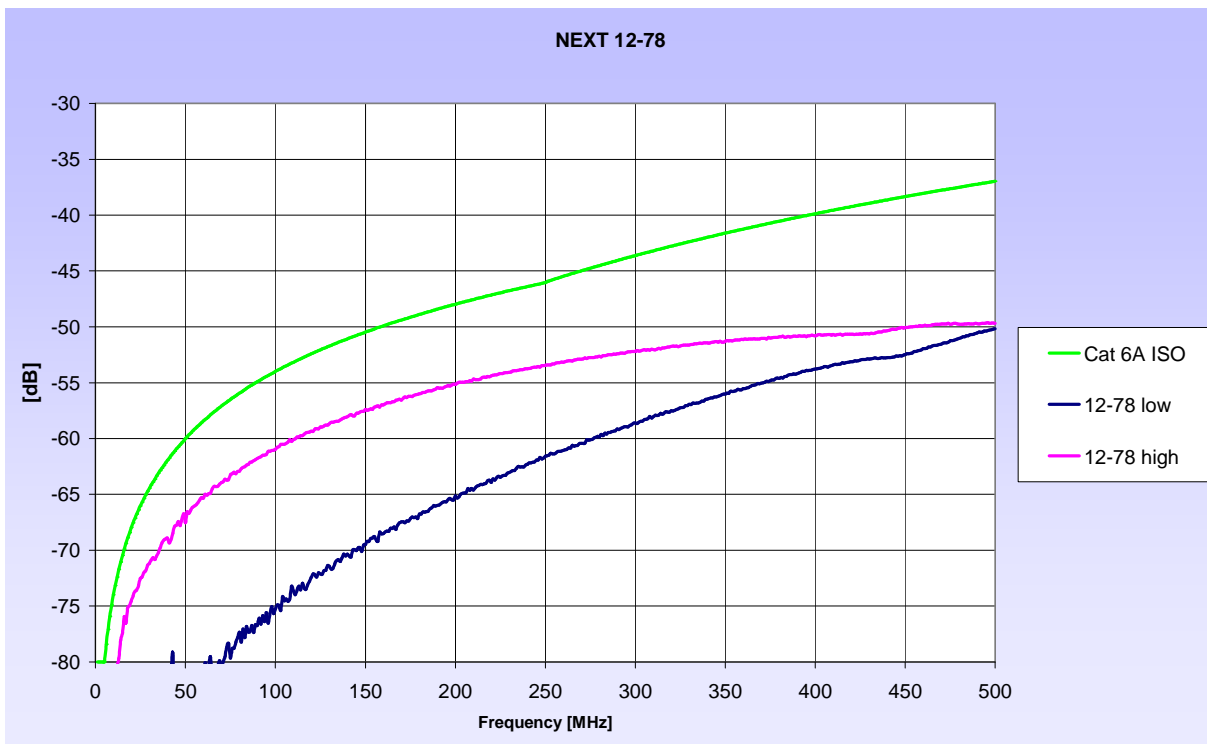

TCL

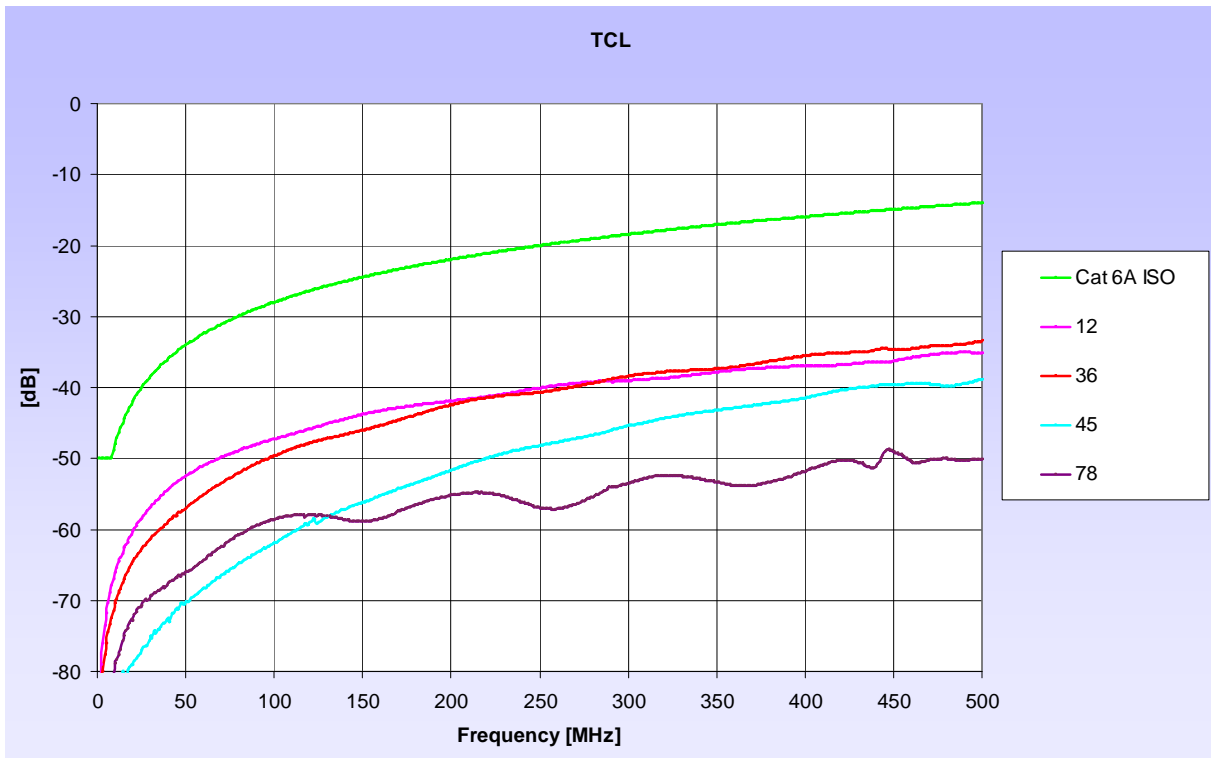

PSANEXT

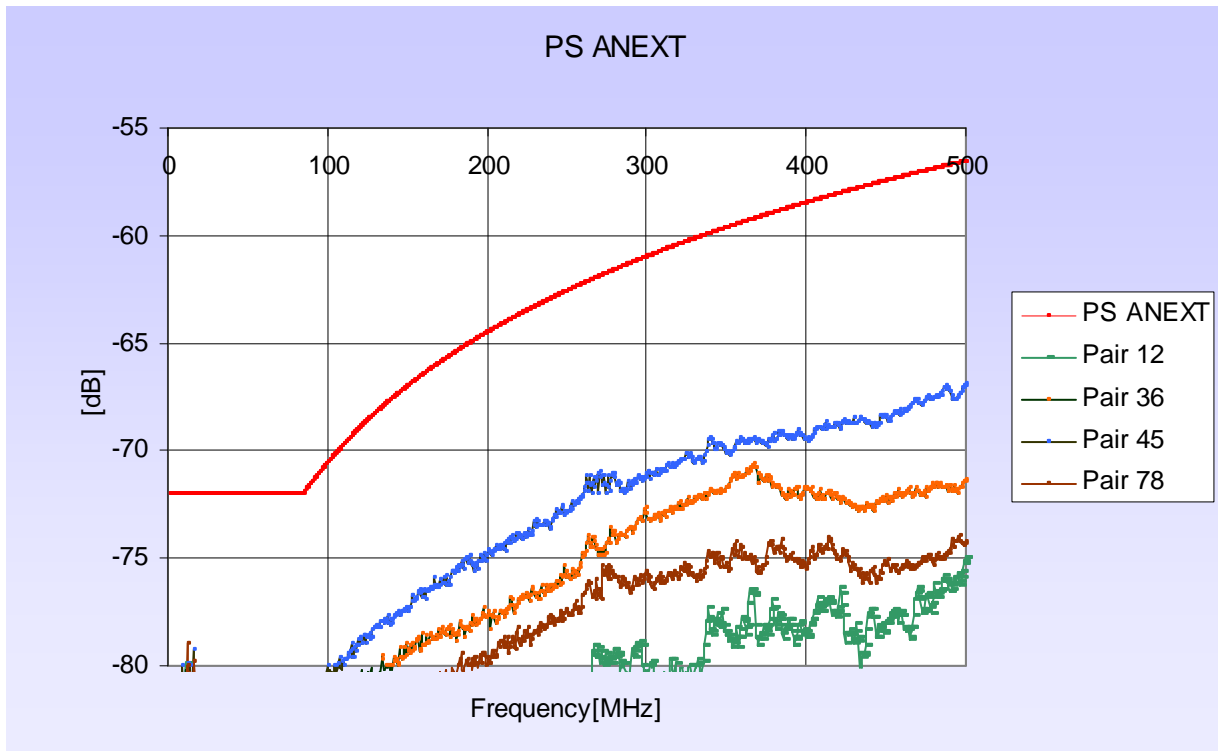

Keystone Cut-out

The keystone adapter ensures that the module will fit in keystone cut-outs as defined in IEC60603-7 ed. 3 Annex D.

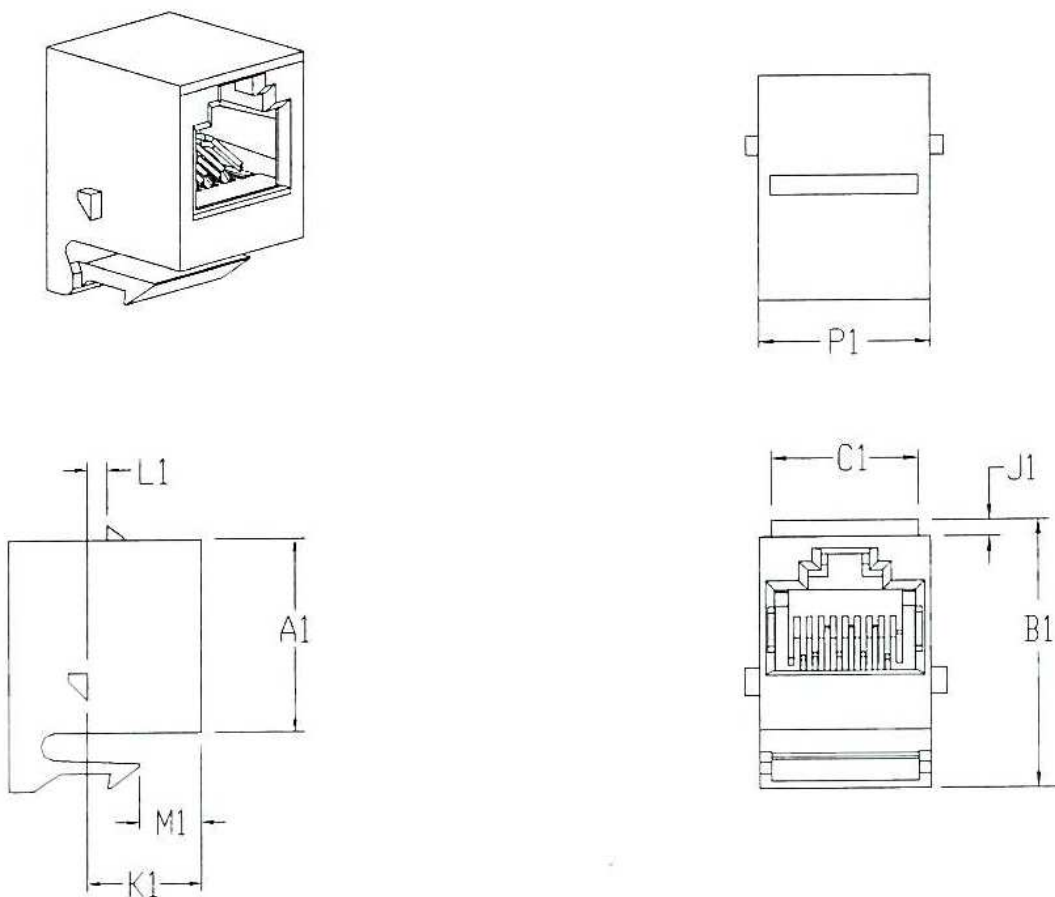

Connector dimensions

Letter	Maximum	Minimum
	mm	mm
A ₁	16.51	16.00
B ₁	22.43	22.07
C ₁	12.65	12.34
J ₁	1.65	1.17
K ₁	9.78	9.53
L ₁	1.75	1.55
M ₁	5.46	5.16
P ₁	14.61	14.35

Mounting Dimensions

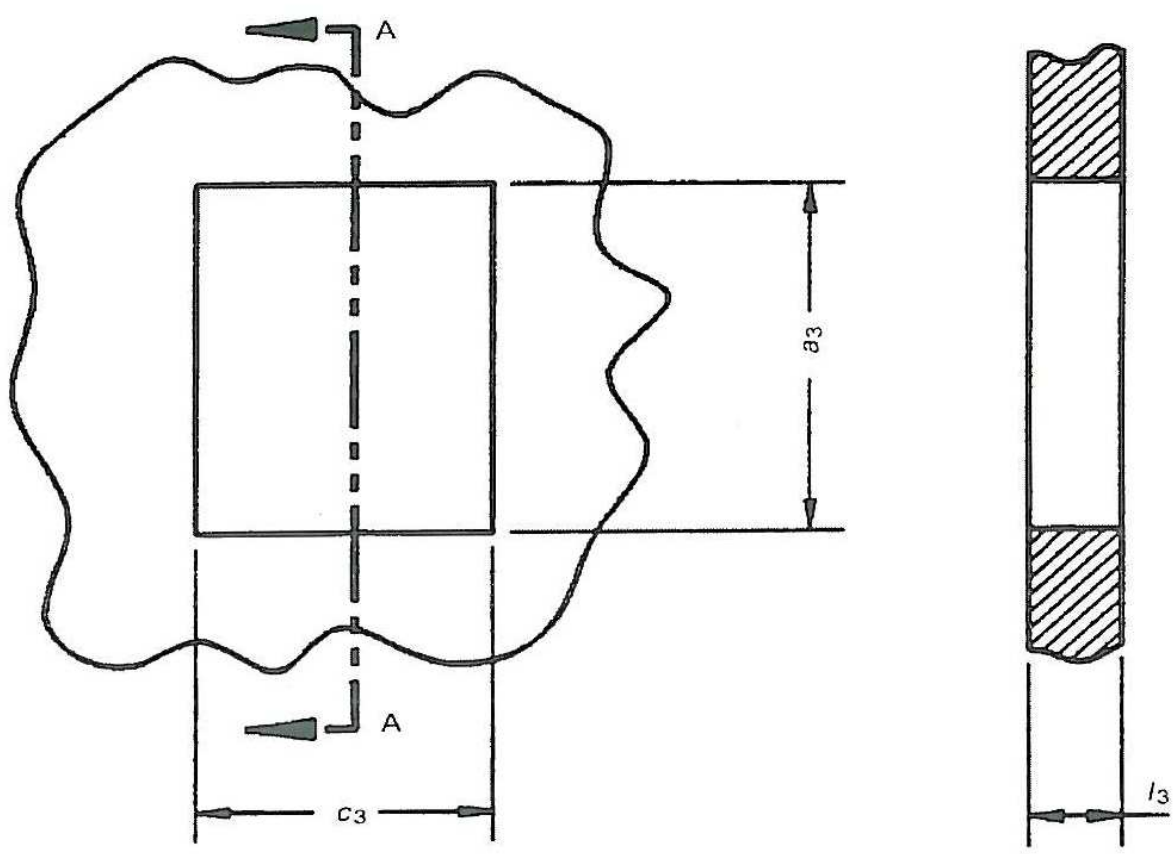

Section A-A

Letter	Maximum	Minimum
	mm	mm
a ₃	19.61	19.30
c ₃	15.04	14.78
l ₃	1.54	1.22