

Power Quality Application Guide

Active Harmonic Conditioners

3.3.3

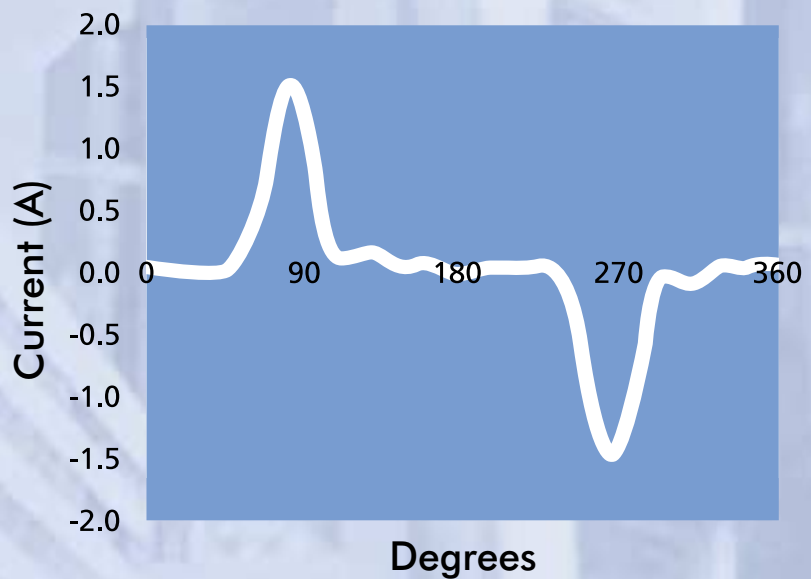

Harmonics

Active Harmonic Conditioners

Shri Karve
MGE UPS Systems Ltd
March 2001

(Version 0b November 2001)

European Copper Institute (ECI)

The European Copper Institute is a joint venture between ICA (International Copper Association) and IWCC (International Wrought Copper Council) contributing members. Through its membership, ECI acts on behalf of the world's largest copper producers and Europe's leading fabricators in promoting copper in Europe. Formed in January 1996, ECI is supported by a network of ten Copper Development Associations ('CDAs') in Benelux, France, Germany, Greece, Hungary, Italy, Poland, Scandinavia, Spain and the UK. It furthers the efforts initially undertaken by the Copper Products Development Association, formed in 1959, and INCRA (International Copper Research Association) formed in 1961.

Copper Development Association (CDA)

Copper Development Association is a non-trading organisation sponsored by the copper producers and fabricators to encourage the use of copper and copper alloys and to promote their correct and efficient application. Its services, which include the provision of technical advice and information, are available to those interested in the utilisation of copper in all its aspects. The Association also provides a link between research and the user industries and maintains close contact with the other copper development organisations throughout the world.

Acknowledgements

This project has been carried out with the support of the European Community and International Copper Association, Ltd.

Disclaimer

European Copper Institute, Copper Development Association and MGE UPS Systems Ltd disclaim liability for any direct, indirect, consequential or incidental damages that may result from the use of the information, or from the inability to use the information or data contained within this publication.

Copyright© European Copper Institute, Copper Development Association and MGE UPS Systems Ltd.

Reproduction is authorised providing the material is unabridged and the source is acknowledged.

♀ Copper Development Association

Copper Development Association
Verulam Industrial Estate
224 London Road
St Albans AL1 1AQ
United Kingdom

Tel: 00 44 1727 731200
Fax: 00 44 1727 731216
Email: copperdev@compuserve.com
Websites: www.cda.org.uk and www.brass.org



European Copper Institute
168 Avenue de Tervueren
B-1150 Brussels
Belgium

Tel: 00 32 2 777 70 70
Fax: 00 32 2 777 70 79
Email: eci@eurocopper.org
Website: www.eurocopper.org

Harmonics

Active Harmonic Conditioners

In little more than ten years, power quality has grown from a specialist interest to an issue of major concern. Businesses are increasingly reliant on electrical power for critical loads, while the increasing population of power electronics-based loads is increasing harmonic distortion in the supply system. Power conditioning equipment is becoming more important for electric utilities and their customers.

Introduction

The problems caused by harmonic currents in installations and the supply network are discussed in Section 3.1. A large proportion of the industrial, commercial and domestic load is now non-linear and the distortion level on the low-voltage distribution network has become a serious concern. The potential problems that could be caused by excessive harmonic voltage on the supply network were recognised long ago, and procedures and standards put in place to limit the distortion. This has been very successful in that problems experienced by customers are nearly always due to conditions within their own site and only rarely imported from the network. If this situation is to be maintained, then consumers must limit the harmonic current they draw. Consequently, customers must ensure that harmonic filtration is provided, where necessary, to achieve this. Generically speaking, there are three methods available, each with particular advantages and disadvantages. They are:

- ◆ Passive filters
- ◆ Transformer solutions - isolation, zig-zag, vector grouping
- ◆ Active filters

This section discusses active filters, sometimes called Active Harmonic Conditioners (AHC). The examples used here relate to the commercial version produced by MGE UPS Systems Limited and sold under the trade name 'SineWave'.

Harmonic mitigation equipment may be provided either to satisfy the electricity supplier (i.e. to meet the requirements of G5/4 or local equivalent) or to deal with the problems arising from the harmonic currents within the site. The position and selection of the equipment will be dependent on the particular circumstances and will usually require a detailed harmonic survey.

Where information technology (IT) equipment is in use, all odd harmonics will be present leading to problems such as the overloading of neutrals by triple-N (i.e. the odd multiples of three) harmonics. Such problems can be eased by good design practice - by rating the cables correctly at installation time - but, often, changes in building function and layout mean that these problems arise long after the building has been commissioned. The problem is compounded by the fact that office accommodation is frequently re-organised, so that circuits that were once relatively 'clean' become heavily polluted. In other words, the harmonic culture of the building changes as new equipment is added and existing equipment relocated. These changes are usually planned without regard to the effect that they may have on the electrical infrastructure.

Replacing cables in a working building can be very expensive and far too disruptive to contemplate, so other mitigation methods are required. Passive filters are possible, but it is quite difficult to design an efficient third harmonic passive shunt filter. Any passive filter will deal only with harmonic frequencies it was designed for, so individual filters will be required for other troublesome frequencies. In any case, as the harmonic culture changes, passive filters may have to be replaced or supplemented. Zig-zag transformers and delta wound isolation transformers are effective against triple N harmonics but have no effect on other harmonics. In this type of application, the active harmonic conditioner is a very good solution.

Topologies of active harmonic conditioners

The idea of the active harmonic conditioner is relatively old, however the lack of an effective technique at a competitive price slowed its development for a number of years. Today, the widespread availability of insulated gate bipolar transistors (IGBT) and digital signal processors (DSP) have made the AHC a practical solution.

Active Harmonic Conditioners

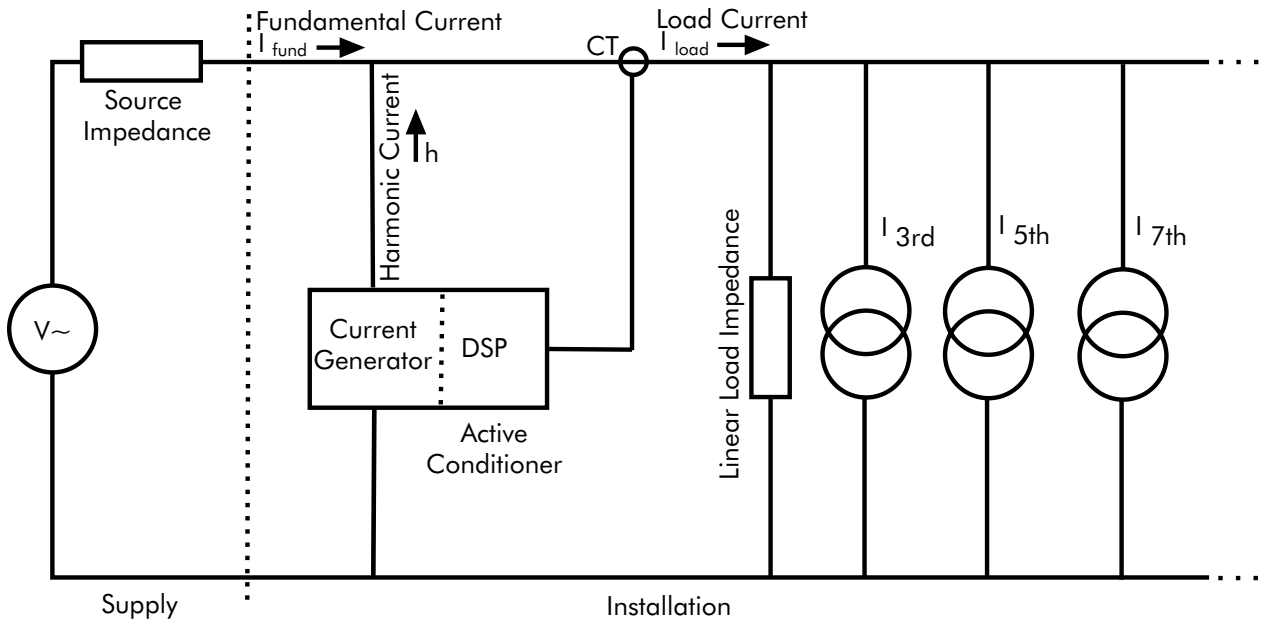

Figure 1 - Parallel active harmonic conditioner

The concept of the AHC is simple; power electronics is used to generate the harmonic currents required by the non-linear loads so that the normal supply is required to provide only the fundamental current. Figure 1 shows the principle of a shunt device.

The load current is measured by a current transformer, the output of which is analysed by a DSP to determine the harmonic profile. This information is used by the current generator to produce exactly the harmonic current required by the load on the next cycle of the fundamental waveform. In practice, the harmonic current required from the supply is reduced by about 90 %.

Because the AHC relies on the measurement from the current transformer, it adapts rapidly to changes in the load harmonics. Since the analysis and generation processes are controlled by software it is a simple matter to programme the device to remove only certain harmonics in order to provide maximum benefit within the rating of the device.

A number of different topologies have been proposed and some of them are described below. For each topology, there are issues of required components ratings and method of rating the overall conditioner for the loads to be compensated.

Series conditioners

This type of conditioner, connected in series in the distribution network, compensates both the harmonic currents generated by the load and the voltage distortion already present on the supply system. This solution is technically similar to a line conditioner and must be sized for the *total load* rating.

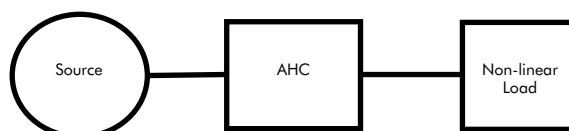

Figure 2 - Series conditioner

Active Harmonic Conditioners

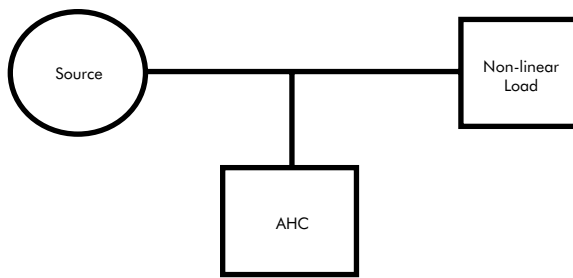

Figure 3 - Parallel conditioner

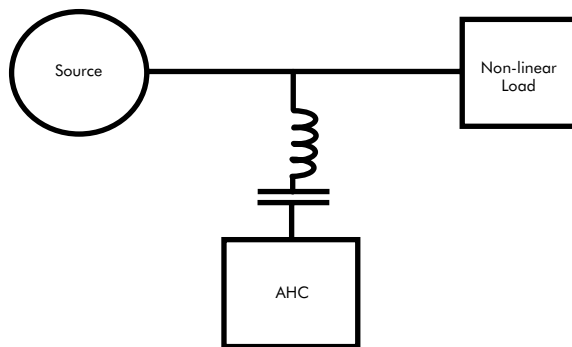

Figure 4 - Hybrid conditioner

Parallel conditioners

Also called shunt conditioners, they are connected in parallel with the AC line and need to be sized only for the *harmonic* power (harmonic current) drawn by the non-linear load(s). This type is described in detail later.

Hybrid conditioners

This solution, combining an active conditioner and a passive filter, may be either of the series or parallel type. In certain cases, it may be a cost-effective solution. The passive filter carries out basic filtering (5th order, for example) and the active conditioner, due to its precise and dynamic technique, covers the other harmonic orders.

Operating principle of the parallel active harmonic conditioner

The active conditioner is connected in parallel with the supply, and constantly injects harmonic currents that precisely correspond to the harmonic components drawn by the load. The result is that the current supplied by the power source remains sinusoidal.

The entire low-frequency harmonic spectrum, from the second to the twenty fifth harmonic, is supported.

If the harmonic currents drawn by the load are greater than the rating of the AHC, the conditioner automatically limits its output current to its maximum rating; the conditioner cannot be overloaded and will continue to correct up to the maximum current rating. Any excess harmonic current will be drawn from the supply; the AHC can run permanently in this state without damage.

Points of connection and configuration

The AHC may be installed at different points in the distribution system:

- ◆ Centrally, at the point of common coupling (PCC), for global compensation of harmonic currents (Figure 5, position A)
- ◆ Partial compensation of harmonic currents (Figure 5, position B)
- ◆ Close to the polluting loads to ensure local compensation of harmonic currents (Figure 5, position C)

Note that the conditioner reacts only to 'downstream' harmonics; a conditioner at position B, for example, would correct only the harmonic current due to loads on feeder S3 and would not react to loads on any other feeder. This allows great flexibility in the design of the conditioning scheme.

As with all harmonic filters, the load side is still polluted by harmonic currents; it is only the supply side circuit that has been cleaned up. Note that load side cables still need to be rated to take account of harmonics and skin effect.

Active Harmonic Conditioners

Ideally, compensation of harmonics should take place at their point of origin. In order to optimise the harmonic compensation, several conditioners may be connected in various configurations. These configurations can be used at any point in the distribution system, offering a total flexibility and a wide choice of compensation strategies. The most common configurations are described in the next two paragraphs.

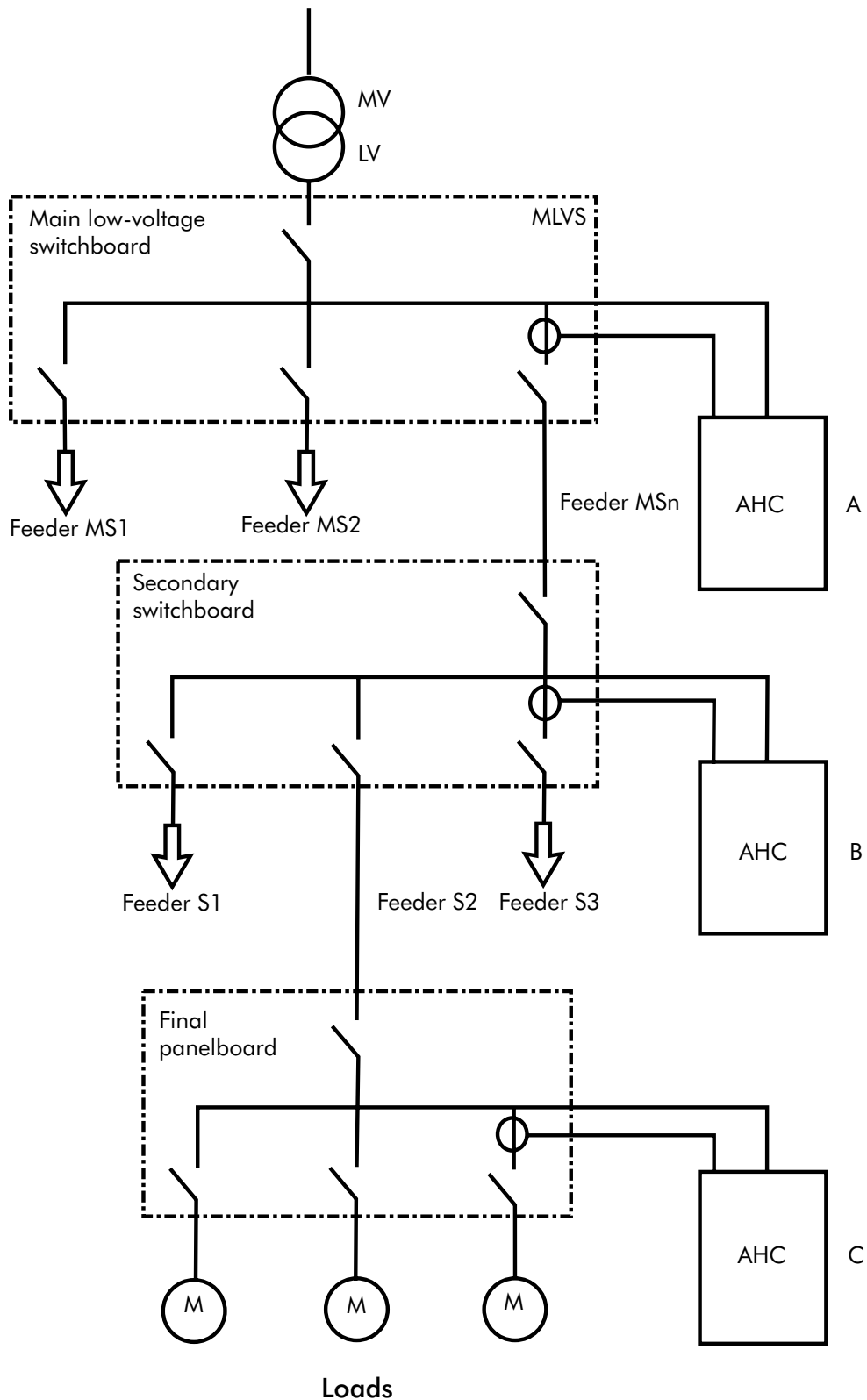

Figure 5 - Three level radial distribution system showing possible connection points for an AHC

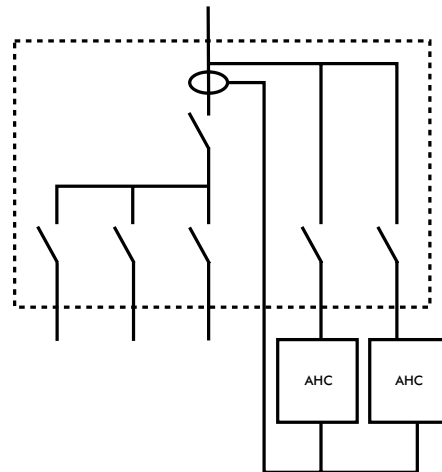

Figure 6 - Parallel configuration

Parallel configuration

This configuration, shown in Figure 6, meets two different requirements:

- ◆ Increased compensation capacity at a given point of the AC system by connecting up to four conditioners of the same rating
- ◆ Increased compensation capacity for any future load expansion
- ◆ Improved reliability by using conditioner of the same rating in redundant operation mode

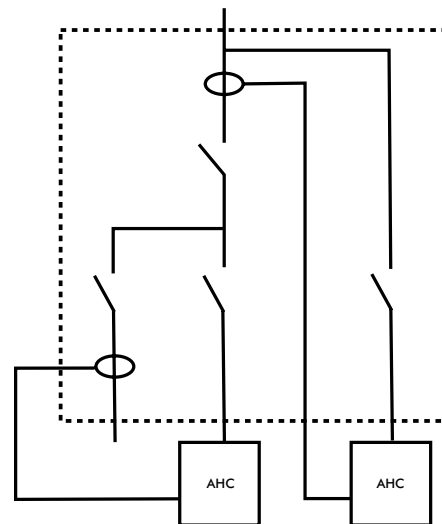

Figure 7 - Cascade configuration

Cascade configuration

This configuration, shown in Figure 7, has the following benefits:

- ◆ Increase the overall compensation capacity using conditioner of the same or different rating
- ◆ Compensate a particular load or harmonic locally and compensate a group of non-linear loads globally.

Application test results

This section presents some typical results of applying the AHC to non-linear loads. The figures illustrate the compensation levels that can be achieved with typical applications in industry and in commercial buildings.

PC type loads

PC type loads are characterised by being rich in all the low order odd harmonics, with very high levels of thirds, fifths, sevenths and ninths. A typical spectrum is shown in Figure 8.

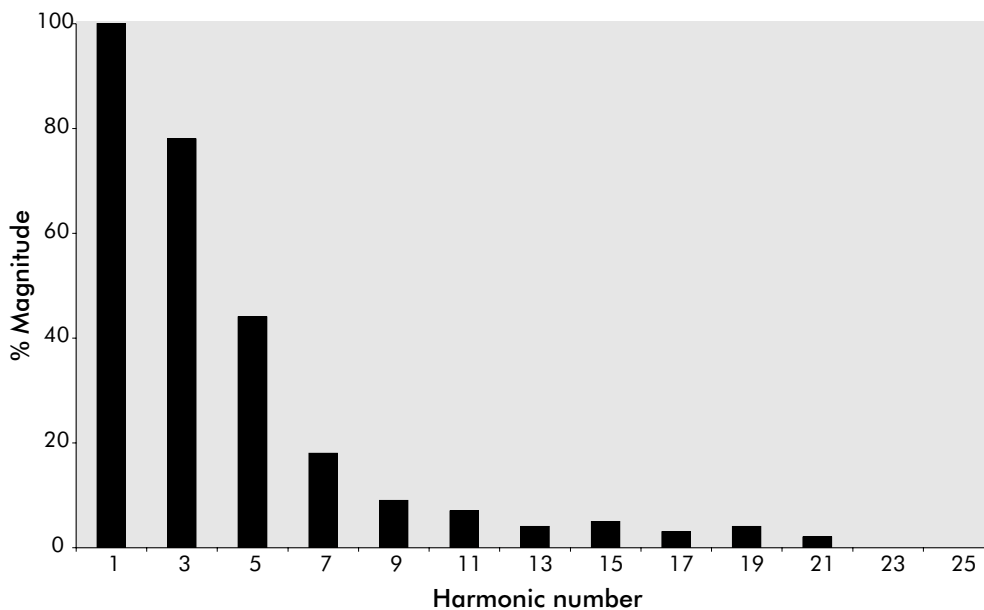

Figure 8 - Uncorrected profile of PC type loads

This type of load causes many problems, including overloaded neutrals, overheating in transformers and heating due to skin effect, as discussed in Section 3.1 of this Guide. Applying an AHC to this load produces the supply current spectrum shown in Figure 9. The improvement is obvious – the THDI (total harmonic current distortion) reduces from 92.6 % to 2.9 % (a factor of 32) and the RMS current is reduced by 21 %.

Complete correction, such as that shown in Figure 9, requires more current from the conditioner. Depending on circumstances, it may not be necessary to eliminate all the harmonic currents. The problems may only be associated with, for example, the third harmonic, and it may be sufficient to deal only with these. Figure 10 shows the effect on supply current of programming the AHC to remove just the third harmonic.

The benefit of this approach is that the problem is solved with lower AHC current so that one conditioner can cope with much more load.

Active Harmonic Conditioners

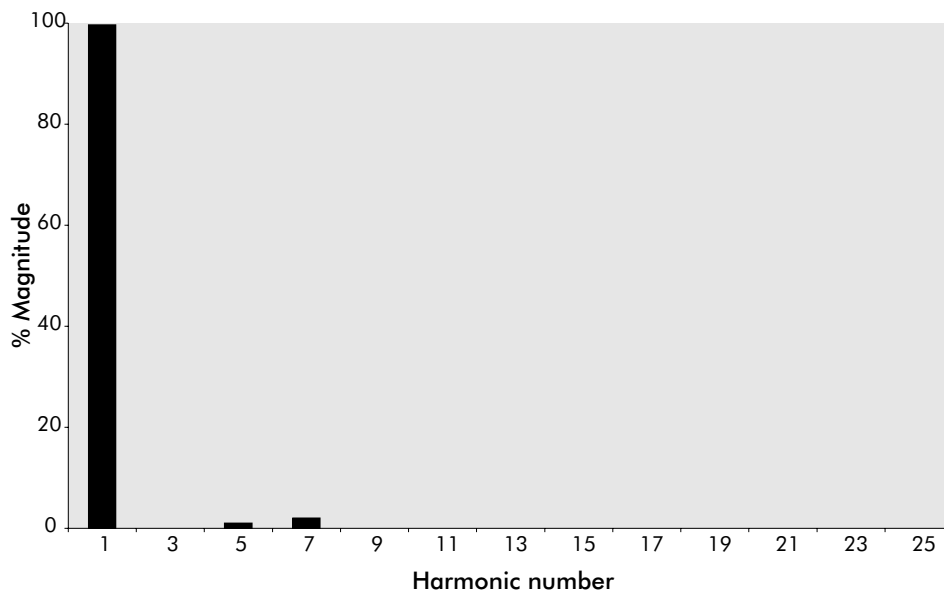

Figure 9 - Completely corrected PC type load

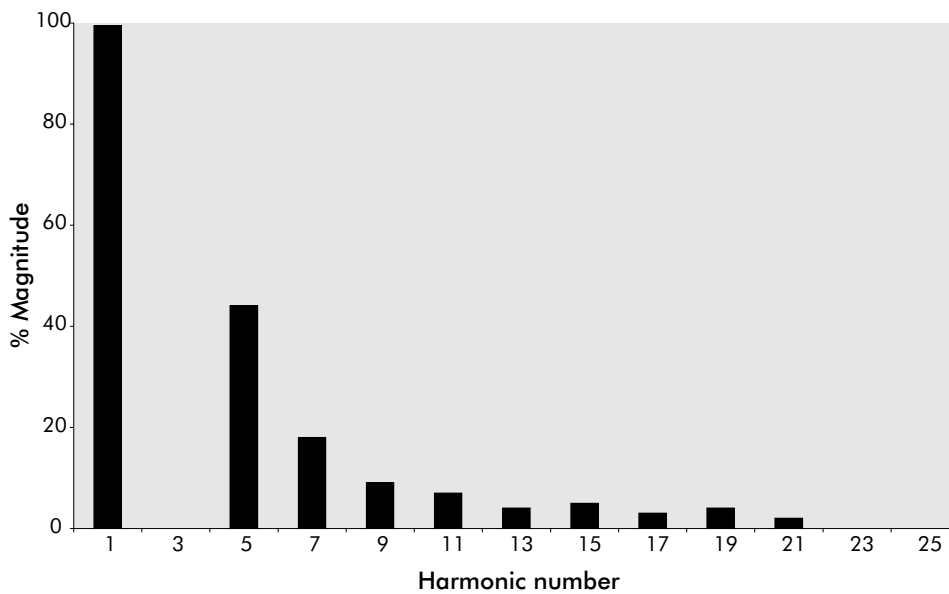

Figure 10 - Partially corrected PC type load

Variable speed drive loads

Figure 11 shows a typical variable speed drive load at part load. The very high fifth and seventh components can cause serious problems in the installation, such as transformer overheating, and can be a serious problem in meeting the supplier's harmonic current limits.

Adding an AHC, and allowing full correction, produces the spectrum shown in Figure 12. In this case the THDI reduces from 124 % to just 13.4 % (a factor of 9.3), with a 30 % reduction in RMS current.

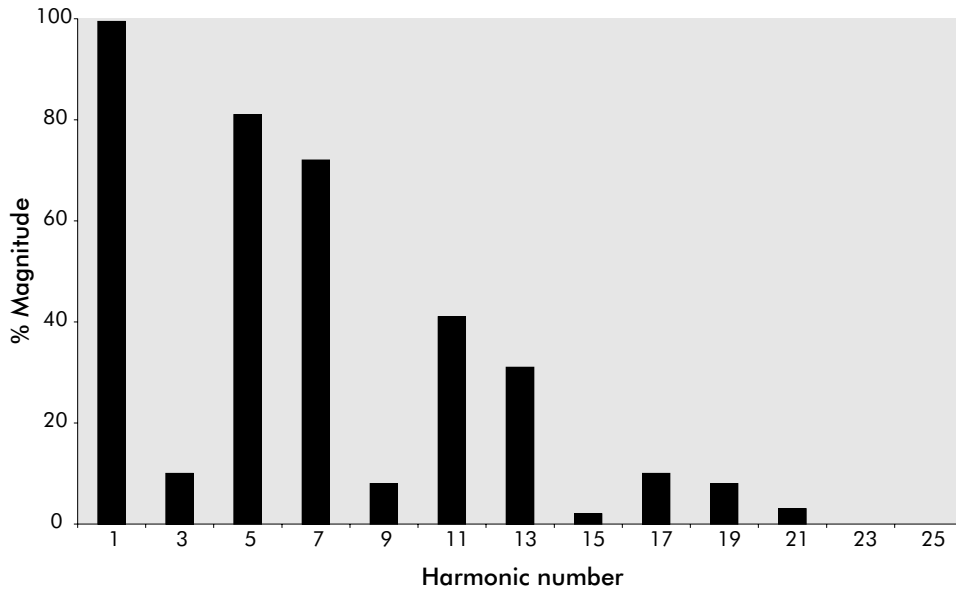

Figure 11 - Typical uncorrected variable speed drive load

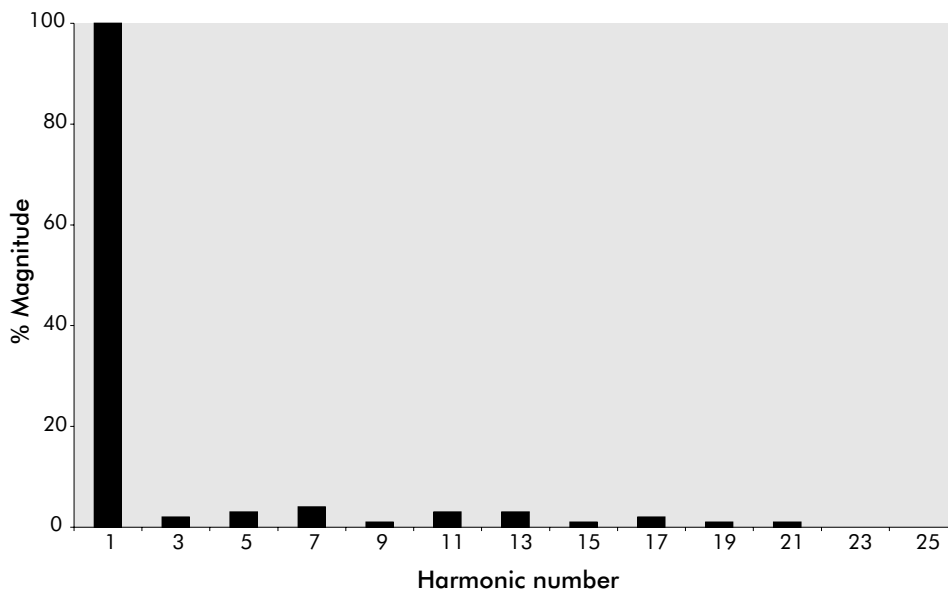

Figure 12 - Corrected variable speed drive type load

Advantages of the AHC

The AHC has the following advantages:

- ◆ Reduces THDI by around 10:1
- ◆ Improves power factor
- ◆ Not affected by frequency variations – e.g. when operating from a standby generator
- ◆ There is no risk of resonance with any harmonic frequency
- ◆ Cannot be overloaded
- ◆ Flexible
- ◆ Can be user programmed to react to specific harmonic frequencies if required.

The AHC provides a simply applied solution to what can be a very complex problem. It is a very flexible solution, making it is easy to cope with changes of building layout and use.

Network Partners

Copper Benelux

168 Avenue de Tervueren
B-1150 Brussels
Belgium

Tel: 00 32 2 777 7090
Fax: 00 32 2 777 7099
Email: mail@copperbenelux.org
Web: www.copperbenelux.org

Contact: Mr B Dôme

Copper Development Association

Verulam Industrial Estate
224 London Road
St Albans AL1 1AQ
United Kingdom

Tel: 00 44 1727 731205
Fax: 00 44 1727 731216
Email: copperdev@compuserve.com
Webs: www.cda.org.uk & www.brass.org

Contact: Mrs A Vessey

Deutsches Kupferinstitut e.V

Am Bonnhof 5
D-40474 Duesseldorf
Germany

Tel: 00 49 211 4796 323
Fax: 00 49 211 4796 310
Email: sfassbinder@kupferinstitut.de
Web: www.kupferinstitut.de

Contact: Mr S Fassbinder

ECD Services

Via Cardinal Maffi 21
I-27100 Pavia
Italy

Tel: 00 39 0382 538934
Fax: 00 39 0382 308028
Email: info@ecd.it
Web: www.ecd.it

Contact: Dr A Baggini

European Copper Institute

168 Avenue de Tervueren
B-1150 Brussels
Belgium

Tel: 00 32 2 777 70 70
Fax: 00 32 2 777 70 79
Email: eci@eurocopper.org
Web: www.eurocopper.org

Contact: Mr H De Keulenaer

Hevrox

Schoebroekstraat 62
B-3583 Beringen
Belgium

Tel: 00 32 11 454 420
Fax: 00 32 11 454 423
Email: info@hevrox.be

Contact: Mr I Hendrikx

HTW

Goebenstrasse 40
D-66117 Saarbruecken
Germany

Tel: 00 49 681 5867 279
Fax: 00 49 681 5867 302
Email: wlang@htw-saarland.de

Contact: Prof Dr W Langguth

Istituto Italiano del Rame

Via Corradino d'Ascanio 4
I-20142 Milano
Italy

Tel: 00 39 02 89301330
Fax: 00 39 02 89301513
Email: ist-rame@wirednet.it
Web: www.iir.it

Contact: Mr V Loconsolo

KU Leuven

Kasteelpark Arenberg 10
B-3001 Leuven-Heverlee
Belgium

Tel: 00 32 16 32 10 20
Fax: 00 32 16 32 19 85
Email: ronnie.belmans@esat.kuleuven.ac.be

Contact: Prof Dr R Belmans

Polish Copper Promotion Centre SA

Pl.1 Maja 1-2
PL-50-136 Wroclaw
Poland

Tel: 00 48 71 78 12 502
Fax: 00 48 71 78 12 504
Email: copperpl@wroclaw.top.pl

Contact: Mr P Jurasz

TU Bergamo

Viale G Marconi 5
I-24044 Dalmine (BG)
Italy

Tel: 00 39 035 27 73 07
Fax: 00 39 035 56 27 79
Email: graziana@unibg.it

Contact: Prof R Colombi

TU Wroclaw

Wybrzeze Wyspianskiego 27
PL-50-370 Wroclaw
Poland

Tel: 00 48 71 32 80 192
Fax: 00 48 71 32 03 596
Email: i8@elektryk.ie.pwr.wroc.pl

Contact: Prof Dr H Markiewicz



MGE UPS Systems Ltd
Orion House
171-177 High Street
Harrow HA3 5EA
United Kingdom

Tel: 00 44 20 8861 4040
Fax: 00 44 20 8861 2812
Website: www.mgeups.com

Shri Karve

Copper Development Association

Copper Development Association
Verulam Industrial Estate
224 London Road
St Albans AL1 1AQ
United Kingdom

Tel: 00 44 1727 731200
Fax: 00 44 1727 731216
Email: copperdev@compuserve.com
Websites: www.cda.org.uk and www.brass.org



European Copper Institute
168 Avenue de Tervueren
B-1150 Brussels
Belgium

Tel: 00 32 2 777 70 70
Fax: 00 32 2 777 70 79
Email: eci@eurocopper.org
Website: www.eurocopper.org